

Glass Clamp - 52x52mm - 316SSS - Satin - 48mm Tube 8-12.76mm (Model: K.GC.5252.316.048.S)

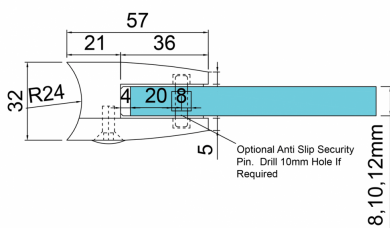
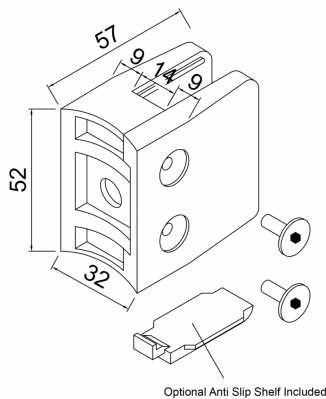

- A 52mm x 52mm square shaped clamp.
- Suitable for mounting on a 48mm diameter post.
- Used mainly outdoors for stairs, glass balconies, pharmaceutical plants, food prep areas and any area subject to moisture.
- Supplied with an optional anti slip safety shelf which ensures that it never allows the glass to slip downwards over time.
- To use these shelves the clamps must be mounted at the corners of the glass panels.
- This clamp is also supplied with the optional anti slip pin which is used when the glass is drilled.
- These clamps are suitable for loads up to approximately 34kgs per four clamps.

Attributes:

Product Code: K.GC.5252.316.048.S

Unit Of Sale: Each

