

SS Covid Counter Protection Post - End - 1000mm (Model: KSS.CP.1000.52.END)

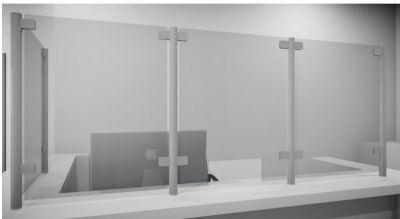

Our counter post system is a fast and stylish way to provide safety screens to staff members and very easily installed.

- Our counter posts are manufactured to the highest quality and in 316 grade stainless steel.
- Optional anti slip shelf mounted in the bottom clamps make these an ideal solution if used for a serve through.
- Can be used with glass, acrylic, polycarbonate, wood, metal etc.
- Easily installed in minutes.
- Left & Right interchangeable
- Manufactured using high grade stainless steel for easy care, maintenance and sanitising
- Manufactured as standard at 1000mm high.
- Other angles, clamp positions and heights are available on request as all the posts are manufactured and fabricated in house.
- 1-2 Weeks delivery due to manufacturing
- Suitable for material 8 - 12.76mm thick.



Attributes:

Product Code: KSS.CP.1000.52.END

Unit Of Sale: Each

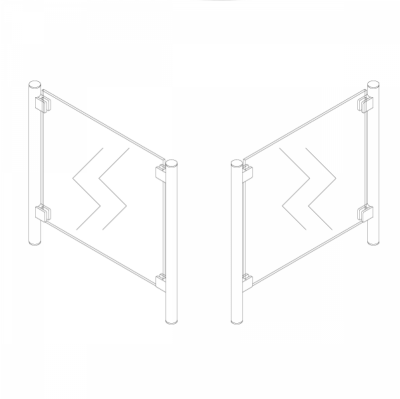
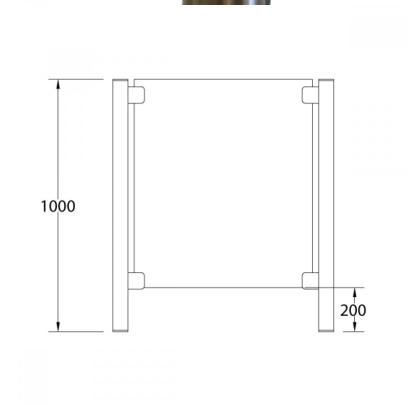
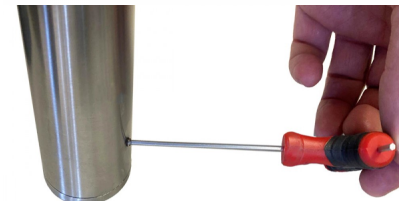
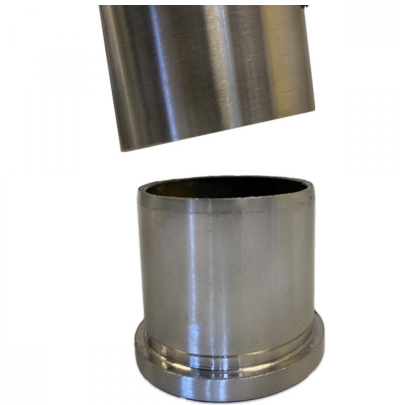
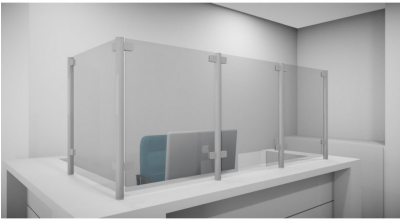
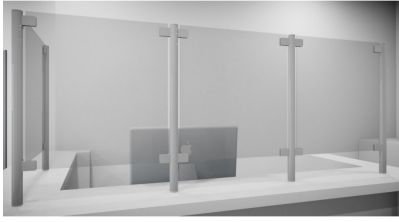

End Post



Easy Assembly

